

CertainTeed Insulation
Building Responsibly

Green and Sustainable Building Information



CertainTeed 
Quality made certain. Satisfaction guaranteed.™





CertainTeed respects the environment through the responsible development of sustainable building products and systems.

Architects, builders, contractors, manufacturers and distributors continue to look for ways to reduce our industry's impact on the environment while meeting customer demand for products that deliver beauty, comfort and performance. As a product that helps reduce the energy needed to heat and cool homes and businesses, CertainTeed Insulation is in the forefront of these efforts. Our commitment is reflected here, highlighting our ongoing effort to become the preeminent supplier of green building materials.

Fiber glass insulation — the original green building material.



CertainTeed insulates buildings by their very nature improve building energy efficiency and reduce energy consumption for the life of the structure, conserving nonrenewable resources, decreasing dependence on foreign oil and lowering greenhouse gas emissions. Sand — an inert, abundant and rapidly renewable resource — is the primary raw material used to make fiber glass. Yet recycled glass has become a significant component of our fiber glass products and is representative of CertainTeed's ongoing effort to reduce our impact on pristine natural resources. Our fiber glass insulation products average 35% recycled glass content (pre- and post-consumer), well exceeding the 20-25% EPA Recovered Material Guideline.

CERTAINTEED INSULATION PLANT LOCATIONS:

Chowchilla, CA • Athens, GA •
Kansas City, KS • Mountaintop, PA •
Sherman, TX

CertainTeed facilities

- › CertainTeed has an ongoing initiative to limit waste and reduce energy consumption at all our insulation plants.
- › CertainTeed manufacturing facilities are switching to high-efficiency fluorescent lamps, which save energy and contain only about one-tenth the mercury found in old metal halide lamps.
- › CertainTeed has also initiated new processes that will reduce the amount of natural gas needed for each unit of fiber glass insulation produced, saving energy and reducing carbon dioxide and nitrogen oxide emissions.
- › CertainTeed is replacing older manufacturing equipment with new, more efficient machinery, which will significantly reduce energy consumption and carbon dioxide emissions.
- › CertainTeed is working with ENERGY STAR to certify our plants as models for energy efficient production.
- › CertainTeed plants use closed-loop water systems that save thousands of gallons of water per year.
- › CertainTeed's Chowchilla, California plant discharges zero wastewater from its manufacturing process, and has created a flexible demand program to decrease the stress on the California electrical grid.
- › Chowchilla also recycles more than 95% of the waste it generates, diverting more than 10 tons of material from landfills every day.
- › CertainTeed values the safety of our employees, and has won numerous safety awards for our diligence in creating safer work environments.

CertainTeed Insulation (general)

- › A typical pound of fiber glass insulation saves twelve times as much energy **in its first year** in place as the energy used to produce it.
- › All CertainTeed insulation products improve building energy efficiency, helping to lower energy costs throughout the life of the structure.
- › All CertainTeed fiber glass insulation products improve acoustical performance and improve overall comfort of buildings.
- › CertainTeed fiber glass insulation lasts for the life of the building, with no maintenance required.
- › CertainTeed fiber glass insulation is currently made with an average of 35% recycled glass.

CertainTeed Insulation (specific products)

- › CertainTeed DryRight™ fiber glass insulation and MemBrain™ Smart Vapor Retarder help keep moisture out of wall cavities, reducing the risk of damaging mold growth and helping to maintain good indoor air quality.
- › CertainTeed fiber glass residential and commercial insulation products are GREENGUARD Children & Schools Certified, ensuring very low or no emissions of volatile organic compounds (VOCs).
- › CertainTeed CertaSpray™ polyurethane spray foam insulation provides an effective air seal, which reduces energy loss and improves indoor air quality.



As homeowners and municipalities become more environmentally conscious, contractors, inspectors and other building professionals are more likely to be asked about adhering to green building standards. CertainTeed insulation products can play an important role in helping a building meet these standards. And as a corporation, CertainTeed is a member of a number of organizations that focus on improving the energy efficiency of buildings and the products used in their construction.

Two of the most well-known of the growing roster of environmentally focused building standards are the Leadership in Energy and Environmental Design (LEED) Green Building Rating System™ and the National Association of Home Builders (NAHB) National Green Building Standards.

The LEED rating system was developed by the U.S. Green Building Council to provide a national benchmark for the design, construction and operation of high performance sustainable buildings. In order for a building to become LEED certified, it must meet certain prerequisites and achieve specified performance levels to qualify for rating points. CertainTeed is a member of the U.S. Green Building Council and supports the LEED program.

NAHB is working with the International Code Council (ICC) to develop an ANSI standard for green building practices. This standard, known as the National Green Building Standard (NGBS), provides a system for certifying homes as green buildings, awarding points to homes based on the design and material choices made in constructing the home. CertainTeed is also an NAHB member company.

CertainTeed insulation is GREENGUARD® Children & Schools Certified. CertainTeed fiber glass insulation has been certified by the GREENGUARD Environmental Institute and meets the most stringent GREENGUARD standards for very low volatile organic compound (VOC) emissions, including formaldehyde.

ENERGY STAR is a joint effort of the U.S. Environmental Protection Agency and the U.S. Department of Energy. Its purpose is to encourage the ongoing development of more energy efficient products and practices. CertainTeed insulation products meet ENERGY STAR specifications, and the company is an Insulation Manufacturer Partner of the program.



6 hybrid insulation system schematics

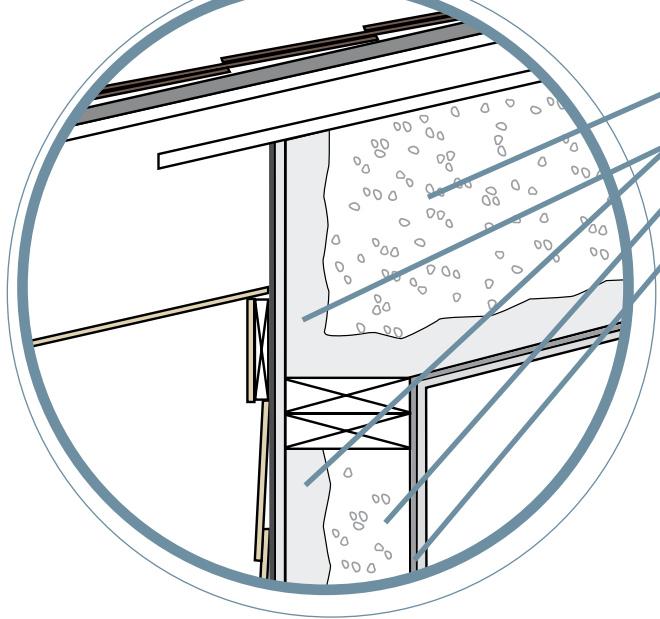

- InsulSafe® SP Premium Blowing Wool
- CertaSpray™ Foam Insulation
- OPTIMA® Loose Fill Fiber Glass
- MemBrain™ Smart Vapor Retarder

CertaSpray™ Foam Insulation
(Apply thermal or ignition barrier – check local code)

DryRight™ Fiber Glass Insulation with
MemBrain™ Smart Vapor Retarder

CertaPro™ Insulation

SoftTouch™ Duct Wrap
ToughGard® 2 Duct Liner
ToughGard® R Duct Liner

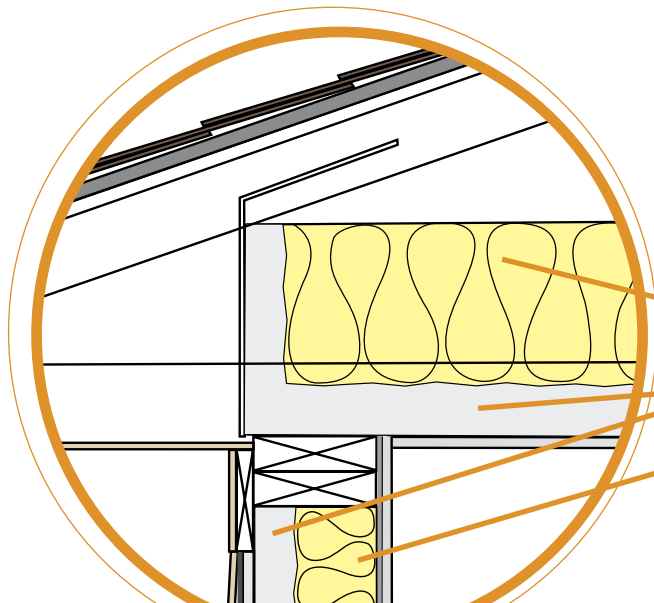
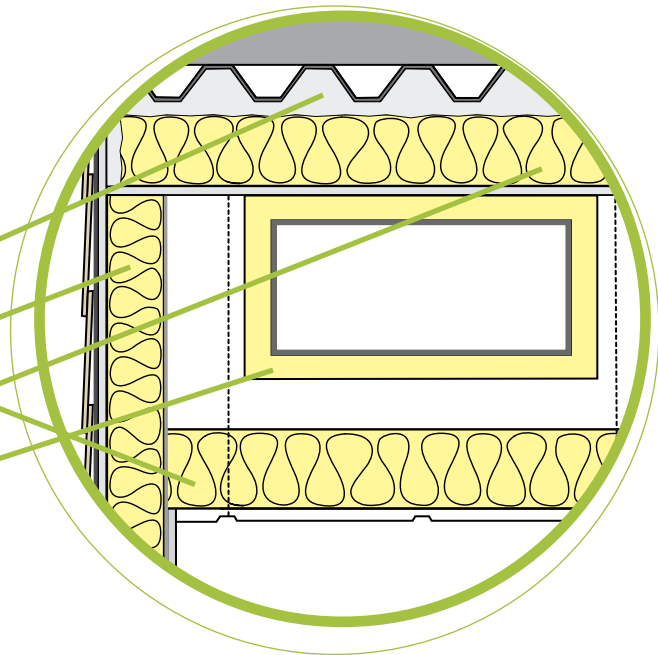

DryRight™ Fiber Glass Insulation with MemBrain™
or CertainTeed Fiber Glass Batt

CertaSpray™ Foam Insulation

DryRight™ Fiber Glass Insulation with MemBrain™

green insulation products at-a-glance

	Insulation – Batts	Insulation – Blowing Wool
Percent Recycled Content	35%	35%
Does Not Emit Harmful Chemicals	✓	✓
Third-party Certifications	GREENGUARD	GREENGUARD
Manufacturing Plant ISO 14001 Certified	✓	✓
ENERGY STAR Partner (P) ¹	P	P
Reduces Carbon Footprint ²	✓	✓
Contributes to Achieving LEED®-NC Credits	✓	✓
Contributes to Achieving LEED®-H Credits	✓	✓
Contributes to Achieving NAHB National Green Building Standard Credits	✓	✓

¹ Contributes to Energy Efficiency – This product reduces the energy consumption of the building in which it is installed by reducing the energy needed to light, heat, and/or cool the building.

² Reduces Carbon Footprint – This product reduces the carbon emissions related to the building in which it is installed either because less fossil fuel was used in its production or installation than comparable materials, or because the product reduces the energy used in the operation of the building (i.e., heating, cooling, lighting, etc.).

buildingresponsibly™

*CertainTeed respects the environment through the responsible
development of sustainable building products and systems.*

ASK ABOUT OUR OTHER CERTAINTEED PRODUCTS AND SYSTEMS:

EXTERIOR: ROOFING • SIDING • WINDOWS • FENCE • RAILING • TRIM • DECKING • FOUNDATIONS • PIPE

INTERIOR: INSULATION • GYPSUM • CEILINGS

CertainTeed Corporation
P.O. Box 860
Valley Forge, PA 19482

Professional: 800-233-8990
Consumer: 800-782-8777
www.certainteed.com

CertainTeed 

NAHB CREDITS*

POSSIBLE POINTS

Resource Efficiency

- 604.1 (2.4.1)†: Use recycled-content building materials for two minor and/or two major components of the building with a recycled content of 25-75%.
- 608.1 (2.8.1): Use indigenous materials for major elements of the building.
- 609.1 (2.8.2): Select the more environmentally preferable product or assembly for an application based upon the use of a Life Cycle Assessment (LCA) tool compliant with ISO 14044 or other recognized standards that compares the environmental impact of building materials, assemblies or a whole building.
- 610.1 (7.1.1): Product manufacturer's operations and business practices include environmental management system concepts and the production facility is ISO 14001 certified.

2-6

2

3

1-10

Energy Efficiency

- 702.2 (3.2.1): Increase building energy efficiency by implementing energy efficiency features to achieve energy cost performance that exceeds International Energy Conservation Code (IECC) requirements by 15-60%.
- 703.1.1 (3.2.1): Total building thermal envelope UA improved by 10-20% over that required by IECC.
- 703.1.2 (3.3.6.1): Insulation is graded by a third party to achieve grade 1 or 2.
- 703.2.1 (3.3.6.1): Insulation and air sealing is installed in walls, floors and ceiling to be in substantial contact with air barriers, subfloor and ceiling surfaces.

30-120

10-36

10-15

3-15

Indoor Environmental Quality

- 901.11: Formaldehyde emissions of wall, ceiling, floor and duct insulation materials are in compliance with California Department of Health (CA 01350), GREENGUARD Children and Schools or SCS Indoor Advantage Gold Program.
- 903.8: All HVAC ducts, plenums, and trunks in unconditioned attics, basements, and crawlspaces are insulated with a minimum of R-6. Outdoor air supplies to ventilation systems are insulated with a minimum of R-6 (mandatory). Two points for R-8.

1

2

* Based on 2007 NAHB National Green Building Standard

† The 600, 700 and 900 series numbers reference the 2007 NAHB National Green Building Standard. The numbers in parentheses reference the equivalent criteria from NAHB's 2006 Model Green Home Building Guidelines, which served as the foundation for the National Green Building Standard.

LEED-H CREDITS**

POSSIBLE POINTS

Innovation & Design

Durability Management Process (credit 2): Contributes to durability of home interior moisture control.

3

Energy & Atmosphere

ENERGY STAR Labeled Home (credit 1.2): Exceed requirements of ENERGY STAR for Homes; home must be third-party inspected.

1-34

Insulation (credit 2.2): Install above code insulation that exceeds 2004 International Energy Conservation Code (IECC) requirements by at least 5% and meets at least Grade 1 specifications (per National Home Energy Rating Standards).

2

Materials & Resources

Environmentally Preferable Products (credit 2.2/Environmentally Preferable Materials): Use products that are environmentally preferable.

0.5

Environmentally Preferable Products (credit 2.2/Environmentally Preferable Materials—Local): Use products that are extracted, processed and manufactured within 500 miles of home.

0.5

Environmentally Preferable Products (credit 2.2/Emission Specifications): Use products that comply with State of California, DHS, "Practice for Testing of VOCs from Building Materials Using Small Chambers."

0.5

** Based on LEED-H January 2008

LEED-NC CREDITS***

POSSIBLE POINTS

Energy & Atmosphere

Minimum Energy Performance (prerequisite 2): Establish minimum level of building energy efficiency per ASHRAE/IESNA Standard 90.1-2004. Insulation is a necessary component to meet this requirement.

Optimize Energy Performance (credit 1): Achieve increasing levels of building energy performance above required minimum performance standards. Additional higher R-Value insulation installed in building envelope can help achieve from 1 to 10 points depending on percentage increase of energy efficiency compared to a base case building.

Materials & Resources

Recycled Content 10-20%: Use materials with recycled content that constitutes at least 10% (credit 4.1) or 20% (credit 4.2) based on the total cost of materials. CertainTeed fiber glass insulation contains pre- and post-consumer glass cullet that can contribute to these credits.

Regional Materials 10-20%: Use building materials/products that have been extracted, harvested or recovered as well as manufactured within 500 miles of project site for a minimum of 10% (credit 5.1) or 20% (credit 5.2) based on the total cost of materials. Depends on location of raw material extraction and manufacturing location in relation to project site.

Indoor Environmental Quality

Thermal Comfort: Design: Design HVAC system and building envelope to comply with ASHRAE Standard 55-2004. Insulation in the building envelope can contribute by helping maintain thermal comfort and humidity within comfort ranges.

Innovation & Design Process

Substantially exceed a LEED performance credit and/or apply strategies that demonstrate a comprehensive approach or quantifiable environmental and/or health benefits. Fiber glass products can contribute to innovation credits for acoustical performance with innovative new products, such as MemBrain™ Smart Vapor Retarder, that improve building assembly performance.

REQ

1-10

1-2

1-2

1

1-4

*** Based on LEED-NC Version 2.2